

# FRONT ROLL RETURN INSTALLATION INSTRUCTIONS

The Roll Return assists the operator in rolling the tarp from the open position to the closed position. Connect PVC pipes together, insert stretch cord, and secure with knot.

**NOTE:** If PVC pipe is not seen after removing end plug, raise crank handle end of roll tube in order for the roll return components to slide out of roll tube.

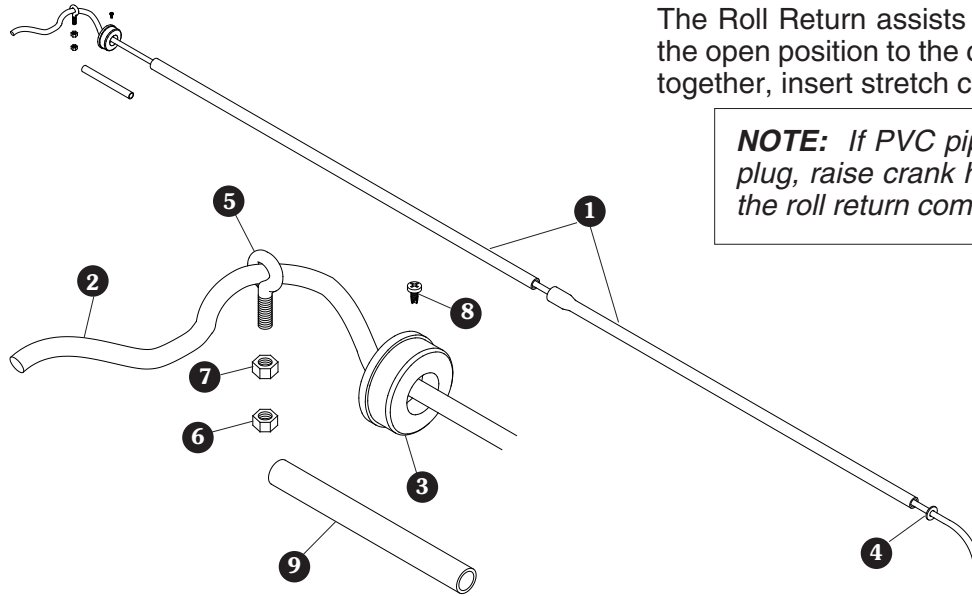

Item	Part #	Description
1	1111067	Roll Return Pipe Set
2	1100169	Stretch Cord, 11'-6"
3	1100138	Nylon End Plug
4	1703373	Flat Washer, 1/2"
5	1700717	Eyebolt, 5/16"
6	1700419	Nylon Lock Nut, 5/16"
7	1700411	Hex Nut, 5/16"
8	1700084	Self-tapping Screw, #8 x 3/8"
9	1107680	Roll Return Cord Cover

**STEP 1:** Press belled PVC pipe over end of straight PVC pipe. Press end plug into end of straight pipe.

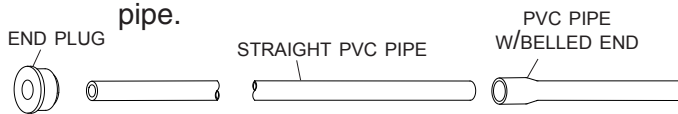

**STEP 2:** Insert stretch cord through pipes and end plug. Slide flat washer on end of stretch rope and tie knot.

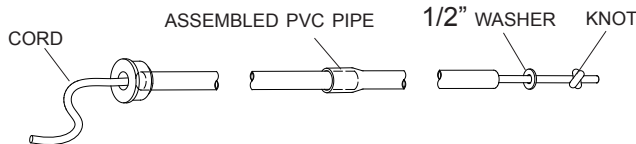

**STEP 3:** Insert roll return assembly into roll tube, lightly tap end plug into place.

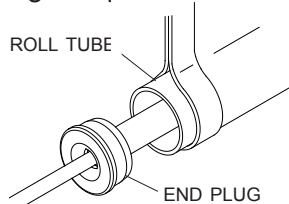

**STEP 4:** Drill 9/64" hole 7/16" from edge of roll return end plug. Secure with #8 self-tapping screw.

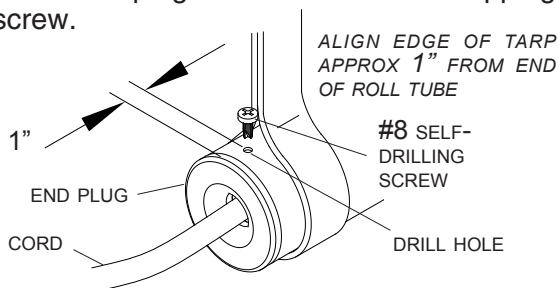

**STEP 5:** Drill 13/32" hole through latch plate 1 1/2" from end. Grind rough edges. Insert eye bolt through hole, secure with 5/16" nut and lock nut.

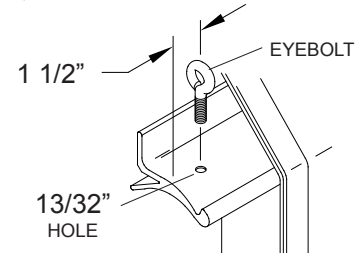

**STEP 6:** With tarp hanging over edge of box, pull stretch cord to remove slack in roll return assembly. Tie knot 6" - 12" from end of rope.

**STEP 7:** Slide protective cover over stretch cord.

**STEP 8:** Thread stretch cord through eye bolt. Tie knot on end of cord, creating enough tension to lift roll return slightly.

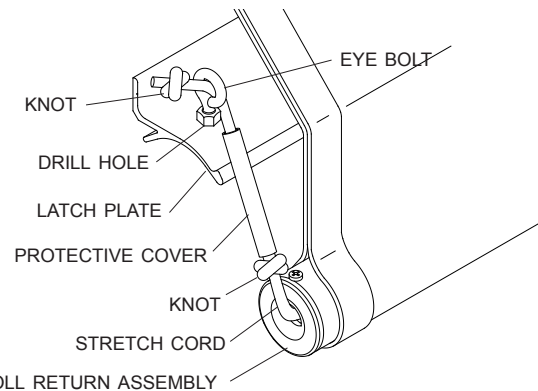

**STEP 9:** Test operation. Cut excess stretch rope and melt any frayed ends.

**Shur-Co.**

P.O. Box 713, 2309 Shur-Lok Street Yankton, South Dakota 57078

Phone: 1-866-748-7435 Fax: (605) 665-0501 Web Site: <http://www.shurco.com>



P/N 1114358 Rev. A