

Item	Part No.	Description
1.	1702707	Ring Terminal - 6 ga. 1/4" Stud
2.	1704330	Rubber Insulating Boot
3.	1118257	Shur-Co. [®] Wireless Receiver
	1119024	Shur-Co. [®] Wireless Receiver SS
	1119346	Shur-Co. [®] Rocker Switch Box SS
4.	1700408	Hex Nut - 1/4"
5.	1700436	Lock Washer - 1/4"
6.	1702926	Cap Screw - 5/16" x 7/8"
	1704430	Cap Screw - 5/16" x 7/8" SS
7.	1201237	Flat Washer - 5/16" SS
8.	1700419	Nylon Lock Nut - 5/16"
	1704431	SS Nylon Lock Nut - 5/16" SS

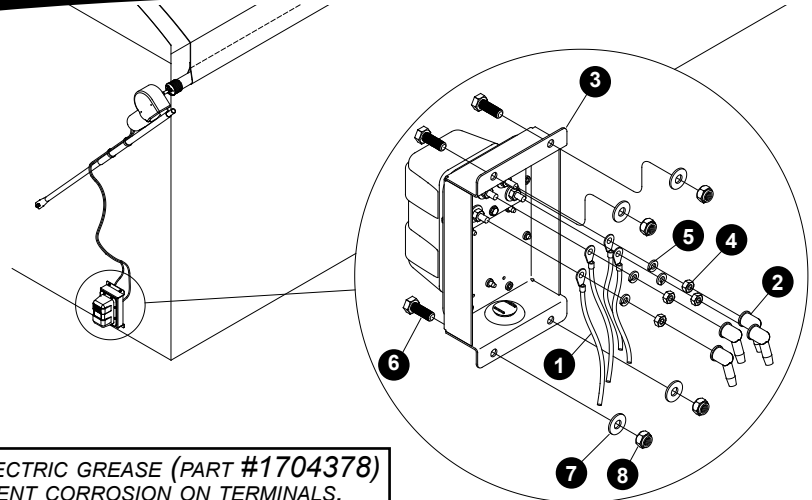

USE DIELECTRIC GREASE (PART #1704378) TO PREVENT CORROSION ON TERMINALS.

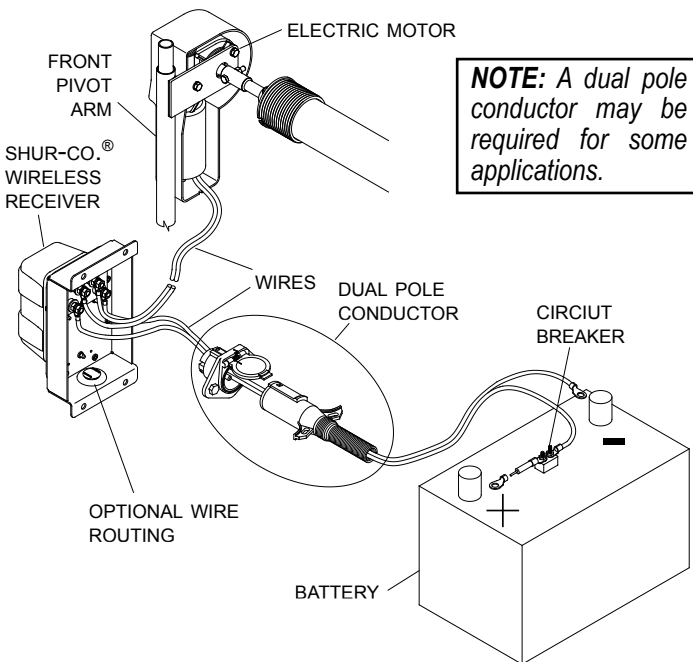

NOTE: A dual pole conductor may be required for some applications.

STEP 1: Identify 6 ga. wire running from electric motor to pivot arm. Route wire as desired. Insert end of this wire through rubber boots, then crimp 1/4" ring terminals onto wire ends. Remove nuts and lock washers from back of receiver. Place positive wire on upper orange post, and negative wire on upper black post. Secure lock washers and hex nuts. Coat with dielectric grease, and install rubber boots over ring terminals.

STEP 2: Run 6 ga. wire from battery to rear hoist pin, and back to wireless receiver. Insert end of wire through rubber boots, then crimp 1/4" ring terminals onto wire ends. Place positive wire on lower orange post, and negative wire on lower black post. Secure with lock washers and hex nuts. Coat with dielectric grease, and install rubber boots over ring terminals.

STEP 3: Mount wireless receiver at suitable location on front of box. Mark and drill 11/32" holes and fasten with 5/16" x 7/8" cap screws, flat washers and lock nuts.

TO ROUTE WIRE THROUGH BOX, DRILL 1 1/4" HOLES AND COVER SHARP EDGES WITH GROMMETS.

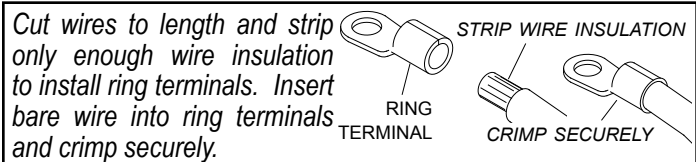

OPERATION

A) Check motor direction by activating switch to "OPEN". If switch is running system backwards, change wire leads on motor to opposite connections.

B) Close tarp: Push switch to "CLOSE" and hold. Observe tarp and release switch when tarp is fully closed.

C) Open tarp: Push switch to "OPEN" and hold. Observe tarp and release switch when tarp is fully opened.

NOTE: Release switch at end of cycle or modified-reset circuit breaker will trip. After breaker resets, switch will activate motor again. To reduce unnecessary strain on tarp components, release switch at end of each cycle.

NOTE: Pressure Wash - Receiver may be pressure washed, but keep nozzle at least three feet from system while spraying.