

PROTRAP FOR CORNHUSKER INSTRUCTIONS

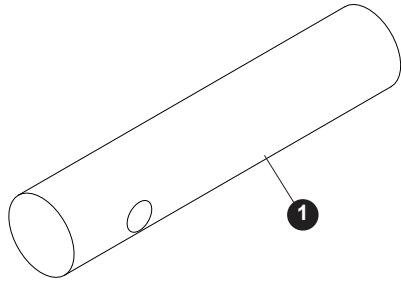

Item Part No. Part Name

- 1118339 Hopper Parts Kit, Cornhusker
- 1. 1118308 Adapter Shaft, Cornhusker

STEP 1: Follow instructions in ProTrap manual to determine crank shaft length.

STEP 2: After cutting square crank shaft to length, insert adapter shaft 2" into crank shaft, leaving drilled hole exposed as shown.

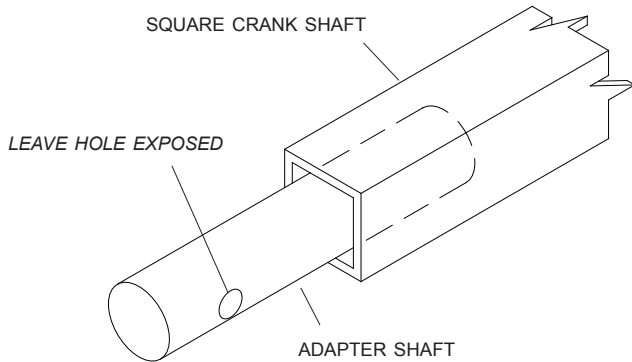

STEP 3: Continue following instructions in ProTrap manual until intermediate bracket is fastened to hinge bracket.

STEP 4: Insert end of adapter shaft into lower coupling on ProTrap motor assembly.

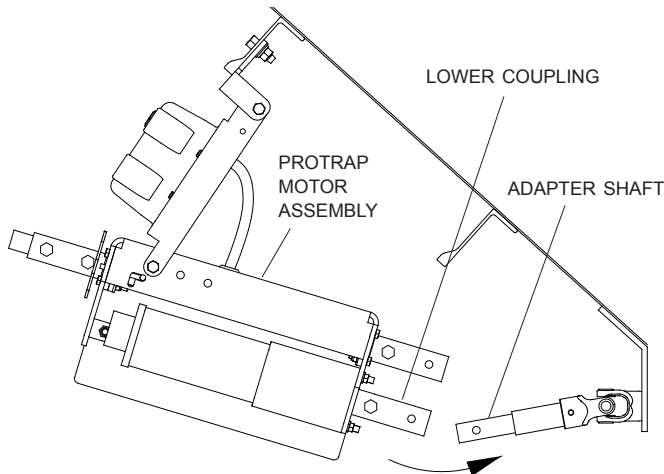

STEP 5: Align holes and insert cap screw. Mark weld location on adapter shaft as shown.

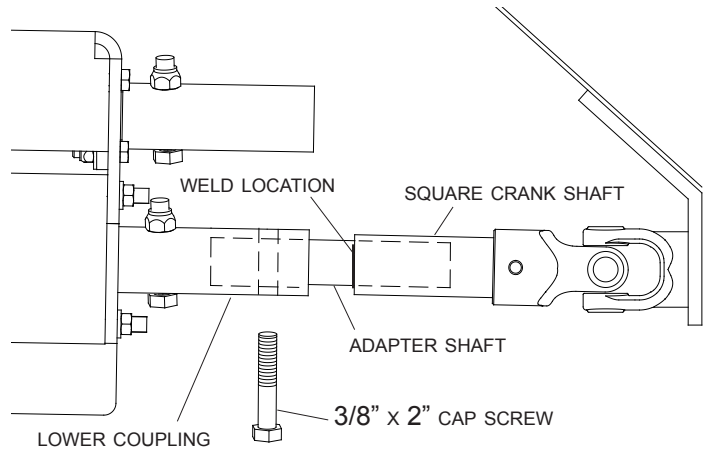

STEP 6: Remove cap screw and disengage ProTrap motor assembly. Align mark on adapter shaft with end of crank shaft. Weld adapter shaft to crank shaft. Repeat Step 4.

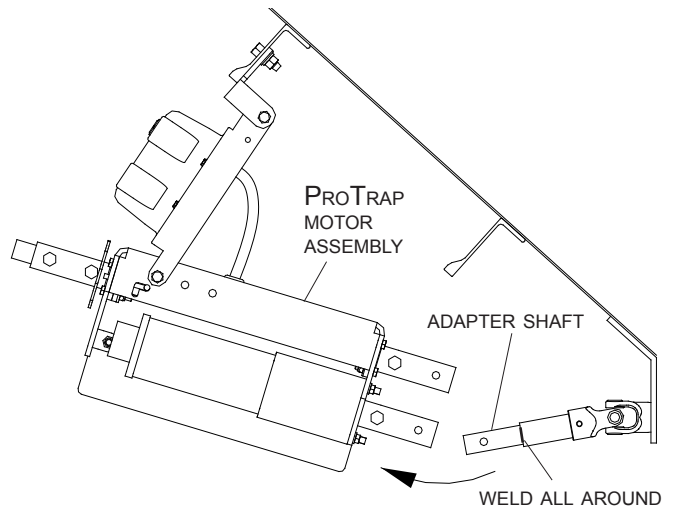

STEP 7: Align holes and fasten as shown in manual.

